

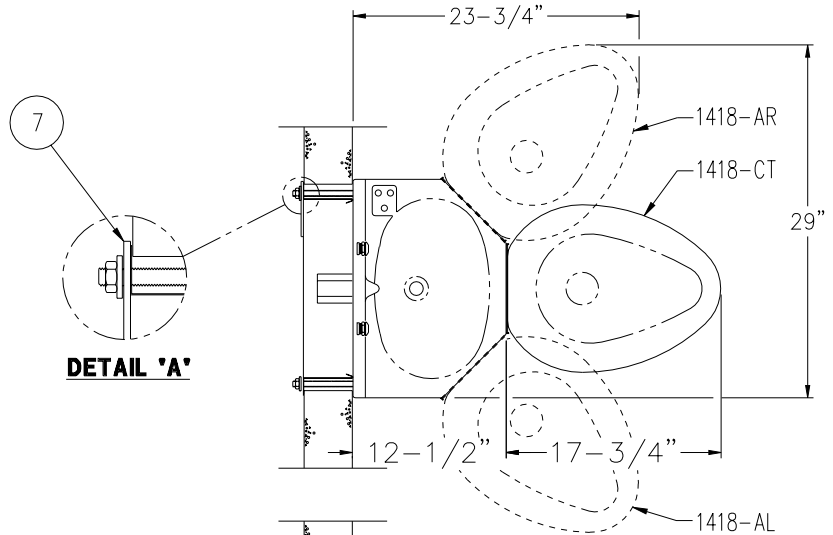

REFERENCE DRAWINGS	
-SW WALL SLEEVE / -MT TEMPLATE	9925-203-001
MOUNTING HARDWARE	9957-900-001
VALVE INSTALLATION:	
-4 AIR-CONTROL (HOT & COLD)	9905-000-003
-3 AIR-CONTROL (SINGLE TEMP.)	9905-001-003

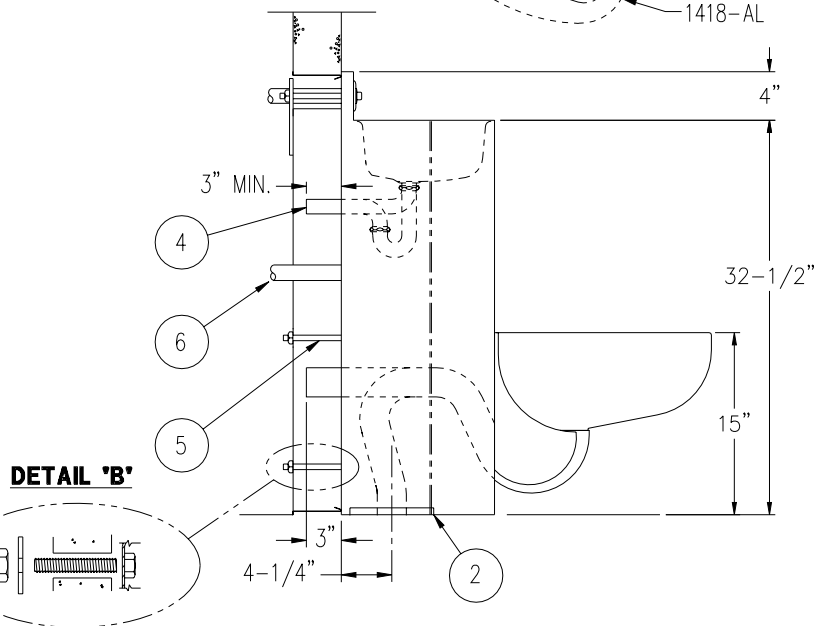

**REAR VIEW OF 1418-CT & 1418-AR UNITS.
1418-AL UNITS OPPOSITE.**

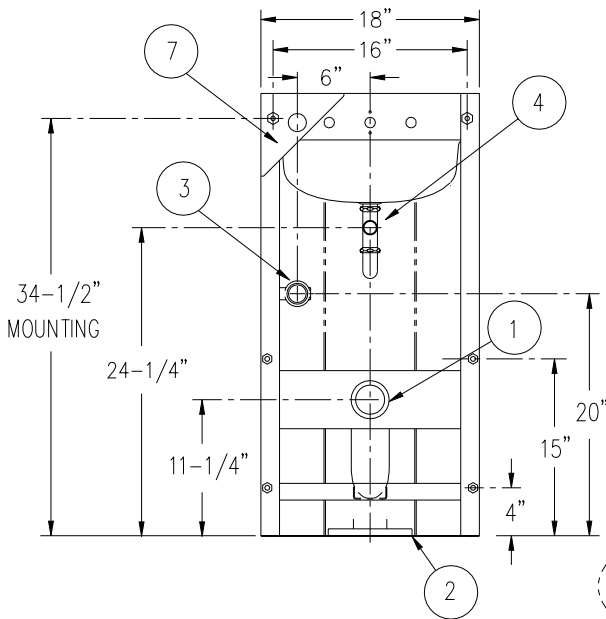

INSTALLATION INSTRUCTIONS:

IMPORTANT: SOME OPTIONS MAY SLIGHTLY ALTER INSTALLATION PROCEDURES. READ ALL SUPPLEMENTAL DRAWINGS BEFORE INSTALLATION OF FIXTURE. ALL FASTENERS, PLATES AND NUTS PROVIDED ARE ESSENTIAL IN PROPERLY ANCHORING THE FIXTURE. ACORN CANNOT ASSUME ANY RESPONSIBILITY FOR UNITS IMPROPERLY INSTALLED.

A- ROUGH-IN PLUMBING FOR THE FOLLOWING CONNECTIONS:

- **TOILET WALL WASTE OUTLET:** 2-3/8" O.D. PLAIN END ①. SUFFIX OPTION -W03 3" O.D. PLAIN END WASTE ①.
- **TOILET FLOOR WASTE OUTLET:** 7-1/2" DIA RECESSED GASKET FLANGE WITH 5/16" TAPPINGS AT 6" O/C ②.
- **FLUSHING INLET CONNECTION** 1-1/2" NPT ③.
- **LAVY WASTE OUTLET** ④ 1-1/2" O.D. PLAIN END STANDARD.
- SEE INDIVIDUAL VALVE SHEET FOR LAVY VALVE ROUGH-IN.

- B- BEFORE FASTENING FIXTURE TO THE WALL, FLOOR OUTLET TYPE FIXTURES MUST BE SET IN PLACE ON WASTE CONNECTION.
- C- SCREW IN (6) 1/2"-13 STUDS ⑤ INTO BACK OF FIXTURE. STUDS MUST HAVE A MINIMUM 1/2" ENGAGEMENT. SCREW IN FLUSHING SUPPLY NIPPLE (1-1/2" IPS) ⑥. MAKE-UP THE LAVY WASTE CONNECTION - 1-1/2" O.D. PLAIN END (SUITABLE FOR A COMPRESSION CONNECTION).
- D- LOCATE FIXTURE INTO PLACE, SLIDING STUDS AND PIPES THROUGH WALL OPENINGS. NOTE: IT MAY BE NECESSARY TO SUPPORT OFF FLOOR FIXTURES ON CELL SIDE OF WALL TO SECURE PROPERLY FROM PIPE CHASE.
- E- SECURE FIXTURE TO WALL USING WASHERS AND/OR PLATE AND NUTS. INSTALL FLUSH VALVE SUPPORT PLATE ⑦ ON FLUSH VALVE SIDE. TORQUE (6) NUTS TO 60FT/LBS. SEE DETAILS A & B.



ACORN ENGINEERING COMPANY
P.O. BOX 3527 INDUSTRY, CA. 91744
(626) 336-4561 FAX (626) 961-2200

TITLE		
18" LAV-TOILET COMBY ANCHORING INSTRUCTIONS CAT. *1418 - CT/AL/AR		
MANUFACTURE DATE	DATE ISSUED	DRAWING NUMBER
MARCH 1999	03-03-99	9925-000-005
TO PRESENT	DATE REVISED	
	11/13/01	

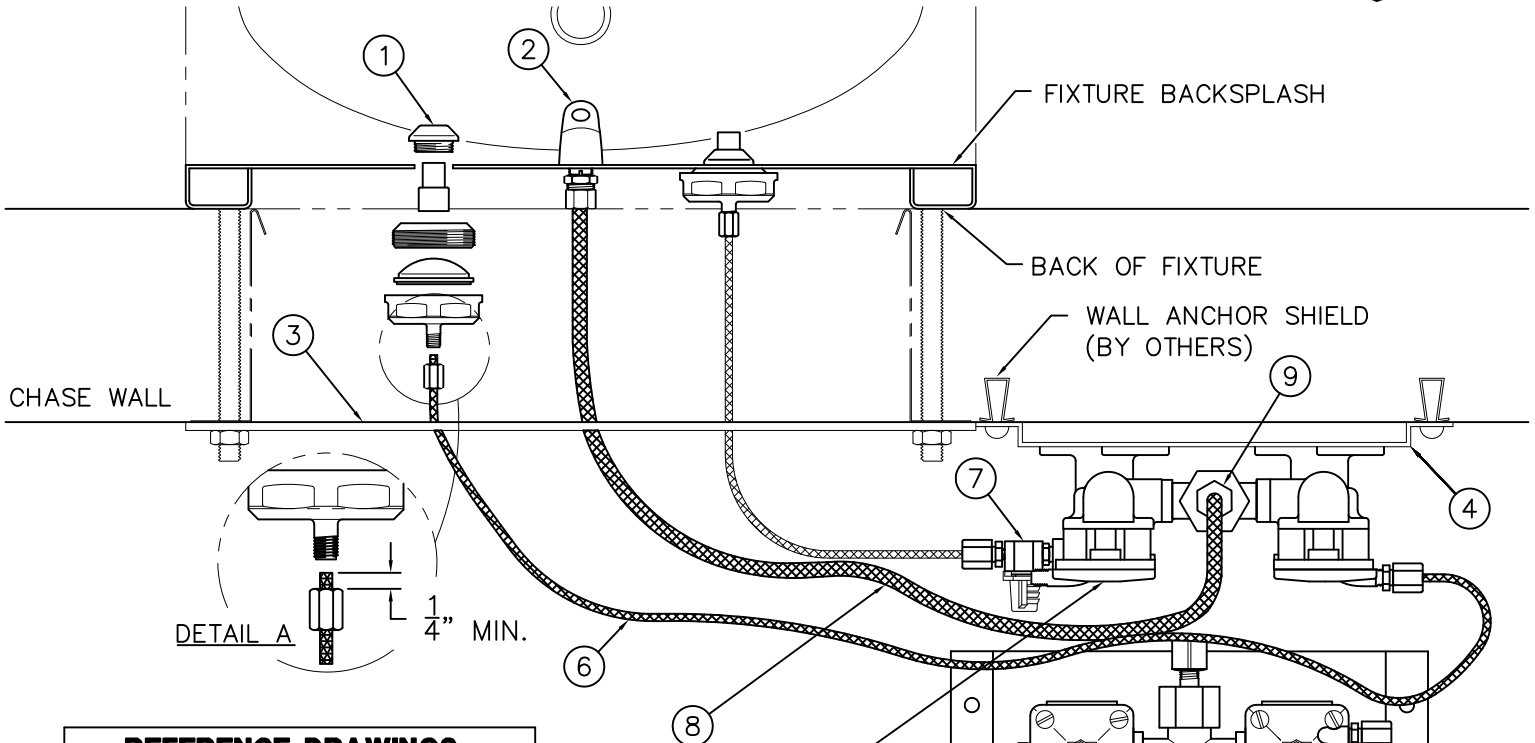

REFERENCE DRAWINGS	
ASSEMBLIES	NUMBER
VALVE BODY	9955-005-003
CHECKSTOP	9956-040-003
FIXTURE TRIM	9957-050-001
-PBH/BPH TRIM	9957-060-001
AIR-CONTROL SERVOMOTORS	
METERING	9955-000-003
NON-METERING	9955-001-003

NOTE:
THIS VALVE
SHOWN w/ (-MH)
METERING, HOT
SIDE ONLY

INSTALLATION INSTRUCTIONS:

- A- PRIOR TO INSTALLATION OF THE FIXTURE, MOUNT PUSHBUTTONS ① AND BUBBLER ② TO THE BACKSPLASH.
- B- INSTALL THE PLUMBING FIXTURE TO THE WALL INCLUDING UPPER SUPPORT PLATE ③.
- C- MOUNT THE AIR-CONTROL VALVE ASSEMBLY ④. LOCATE AS REQUIRED. MAXIMUM ALLOWABLE DISTANCE BETWEEN PUSHBUTTON ① AND AIR-CONTROL SERVOMOTOR ⑤ IS 10 FEET. WALL ANCHORING HARDWARE ARE BY OTHERS.
- D- CONNECT 1/8" O.D. POLYETHYLENE AIR LINES ⑥ TO PUSHBUTTONS ① AND SERVOMOTOR ⑤. HAND TIGHTEN USING FERRULE NUTS PROVIDED. SEE DETAIL A. NOTE: WHEN METERING VALVES ARE SPECIFIED, AIR LINES CONNECT DIRECTLY TO VALVE TIMER ⑦.
- E- CONNECT 1/4" O.D. POLYETHYLENE WATER LINE ⑧ TO BUBBLER ② AND COMPRESSION NUT ⑨. HAND TIGHTEN USING FERRULE NUTS PROVIDED.

NOTE:
MAXIMUM RECOMMENDED WORKING WATER PRESSURE IS 100 PSI; TEMPERATURE IS 130° F; OUTLET TEMPERATURE IS RECOMMENDED AT A MAXIMUM OF 105° F.
WARNING:
PRIOR TO MAKING INSTALLATION, SUPPLY LINES MUST BE FLUSHED OF ALL FOREIGN MATERIAL SUCH AS PIPE DOPE, CHIPS, SOLDER, ETC. VALVE MUST BE DRAINED PRIOR TO BEING SUBJECTED TO FREEZING TEMPERATURES. MAXIMUM RECOMMENDED OUTLET WATER TEMPERATURE IS 105° F.

- F- AFTER THOROUGHLY FLUSHING THE SUPPLY LINES, MAKE-UP 1/2" NPS FEMALE SUPPLY CONNECTIONS. NOTE: SUPPLY INLET CONNECTION WILL ACCOMODATE 1/2" NPT MALE ADAPTER. THREAD FLEX CONNECTOR HOSE ⑩ TO CHECKSTOPS ⑪ AND TO SUPPLY STUB OUTS.
- G- SEE APPROPRIATE SERVOMOTOR REFERENCE DRAWING FOR DETAILS AND TIMING INSRUCTIONS.

ACORN ENGINEERING COMPANY P.O. BOX 3527 INDUSTRY, CA. 91744 (626) 336-4561 FAX (626) 961-2200	TITLE (04-SERIES) HOT & COLD AIR-CONTROL VALVE ASSEMBLY - NEW STYLE	
	MANUFACTURE DATE SEPT 1995 TO PRESENT	DATE ISSUED 11/1/95 DATE REVISED 07/15/10

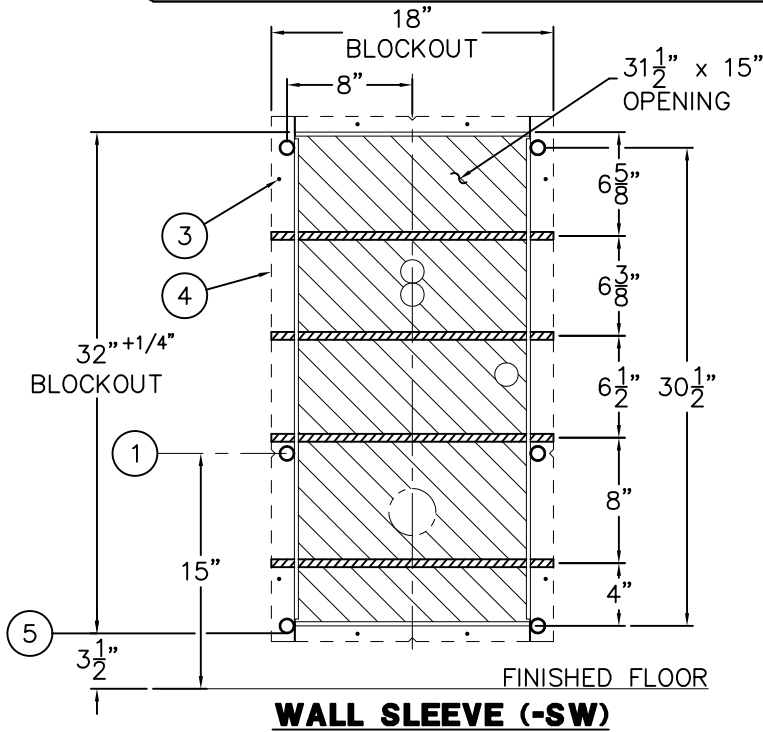

WALL SLEEVE (-SW)

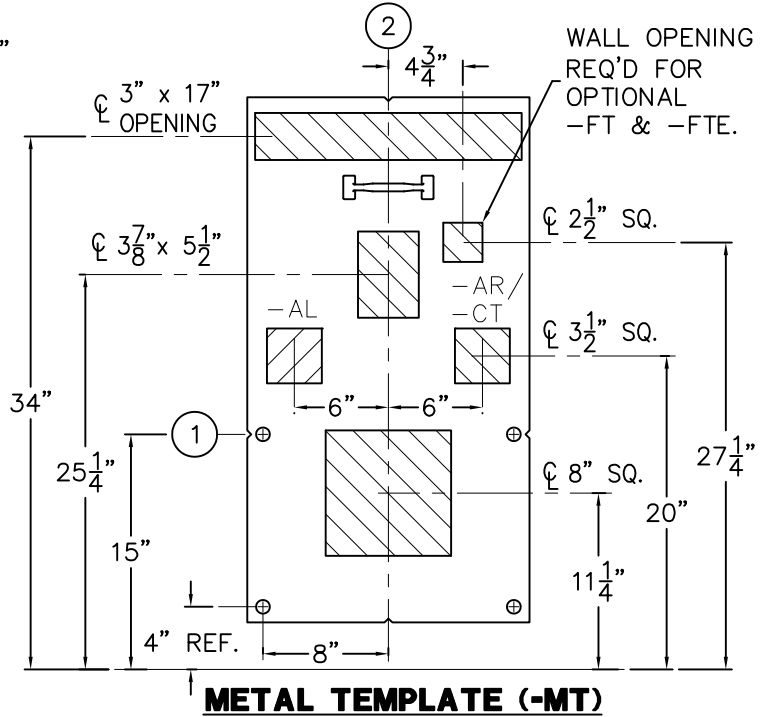

METAL TEMPLATE (-MT)

RIGHT HAND FIXTURE ROUGH-INS SHOWN FROM FIXTURE SIDE, LEFT HAND FIXTURE OPPOSITE

SHADED AREAS ARE REQUIRED WALL OPENINGS

WALL SLEEVE

SLEEVES ARE INSTALLED IN FORMS (USING NAIL HOLES (3) PROVIDED) OR GROUTED INTO BLOCK WALLS, BECOMING A PERMANENT PART OF WALL.

- A. INSTALL SLEEVE WITH FLANGE (4) ON CHASE SIDE OF WALL.
- B. LOCATE TOP AND BOTTOM NOTCHES AT VERTICAL CENTERLINE (2) OF PLUMBING FIXTURE.
- C. LOCATE SIDE NOTCHES (1) AT DIMENSION SHOWN, MEASURED FROM THE FINISHED FLOOR ON CELL (FIXTURE) SIDE.

NOTES:

- 1. FOR POURED WALL CONSTRUCTION, TEMPORARY BRACING SHOULD BE INSTALLED WITHIN SLEEVE OPENING TO PREVENT DEFORMATION TO SLEEVE WHICH MAY OCCUR DURING POUR. DO NOT POUR CONCRETE DIRECTLY ON TOP OF WALL SLEEVE.
- 2. WHEN SLEEVES ARE NOT AVAILABLE BLOCKOUT FOR SLEEVE OPENING IN WALL PER DIMENSIONS SHOWN (5).

METAL TEMPLATE

TEMPLATES ARE USED TO LAYOUT REQUIRED WALL OPENINGS FOR SUBSEQUENT FLAME CUTTING OR CORE DRILLING.

- A. STRIKE A HORIZONTAL CHALKLINE (1) ON THE WALL AT DIMENSION SHOWN, MEASURED FROM THE FINISHED FLOOR ON CELL (FIXTURE) SIDE. THIS WILL LOCATE CENTERLINE FOR HORIZONTAL NOTCHES ON TEMPLATE.
- B. STRIKE A VERTICAL CHALKLINE (2) ON THE WALL TO INDICATE CENTERLINE OF FIXTURE. THIS WILL LOCATE CENTERLINE FOR VERTICAL NOTCHES ON TEMPLATE.
- C. PLACE TEMPLATE AGAINST WALL. LOCATE NOTCHES ALONG CHALKLINES. MARK WALL FOR REQUIRED OPENING.

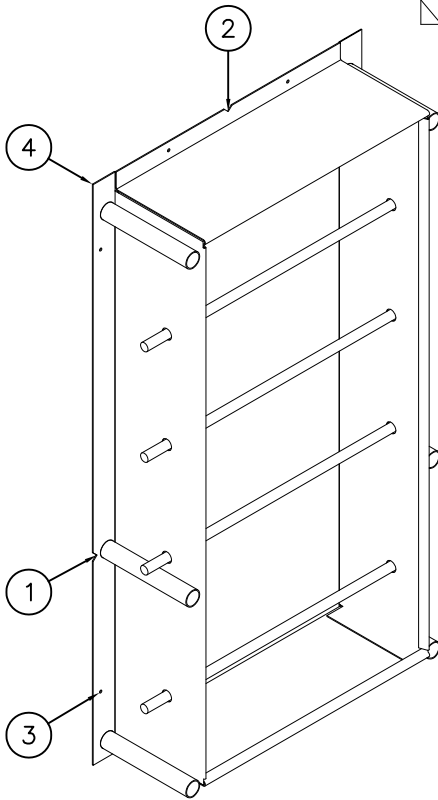

WALL SLEEVE (-SW)

ACORN ENGINEERING COMPANY
P.O. BOX 3527 Industry, CA 91744
15125 Proctor Ave Industry, CA 91746
(626) 336-4561 FAX (626) 961-2200

TITLE **-SW WALL SLEEVE & -MT METAL TEMPLATE CAT# 1418\1440-CT\AL\AR, -VAC**

MANUFACTURE DATE

**JUNE 1971
TO PRESENT**

DATE ISSUED

03/01/90

DATE REVISED

06/10/14 B

DRAWING NUMBER

9925-203-001

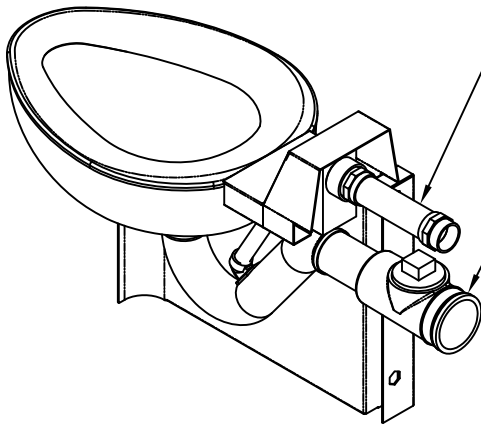

Optional -FVT Flush Valve Thru Wall Connection. Shown For Reference.

Optional -CO1 Waste Fitting. Shown For Reference.

REFERENCE DRAWING	
WASTE CONNECTION WITH CLEANOUT -CO1	9985-125-002

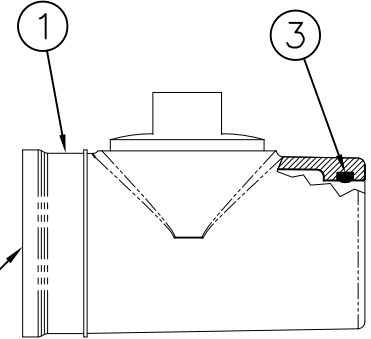

NOTE: Optional -CO1 Waste Fitting Available With 3" or 4" No-Hub

Scaled: X 2

Optional -FVT Flush Valve Thru Wall Connection Shown For Reference

Plain End Extends 3" Beyond Back Of Fixture. Optional Extended Waste Is Available -TWE

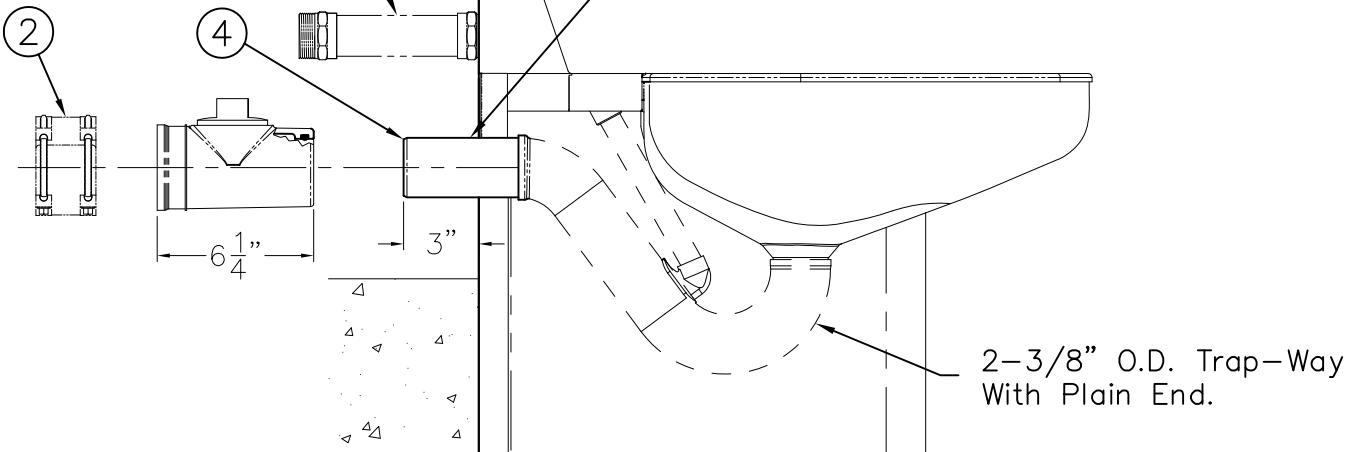

MODEL #1685 SHOWN FOR REFERENCE

INSTALLATION INSTRUCTIONS

A-INSERT O-RING ③ INTO GROOVE OF WASTE FITTING ①. LUBRICATE THE O-RING ③ WITH O-RING LUBRICANT.

B-INSTALL WASTE FITTING ① TO FIXTURE P-TRAP WASTE EXTENSION ④. ENGAGEMENT IS APPROXIMATELY 1-1/4". NOTE: TOILET WASTE

EXTENSION ④ IS 3" BEYOND BACK OF FIXTURE. LONGER WASTE EXTENSION IS AVAILABLE.

C-MAKE UP WASTE FITTING CONNECTION TO WASTE PIPING USING NO-HUB (BAND) CONNECTOR ② BY OTHERS.

ACORN ENGINEERING COMPANY
P.O. BOX 3527 INDUSTRY, CA. 91744
(626) 336-4561 FAX (626) 961-2200

TITLE **NO-HUB WASTE CONNECTION WITH CLEANOUT -CO1**

MANUFACTURE DATE

JULY 1975
PRESENT

DATE ISSUED

1/29/96

DATE REVISED

11/08/13 D

DRAWING NUMBER

9925-054-001



DIMENSION "A"	
UP TO 8" WALL	8" TO 12" WALL
15-1/8"	19-1/8"

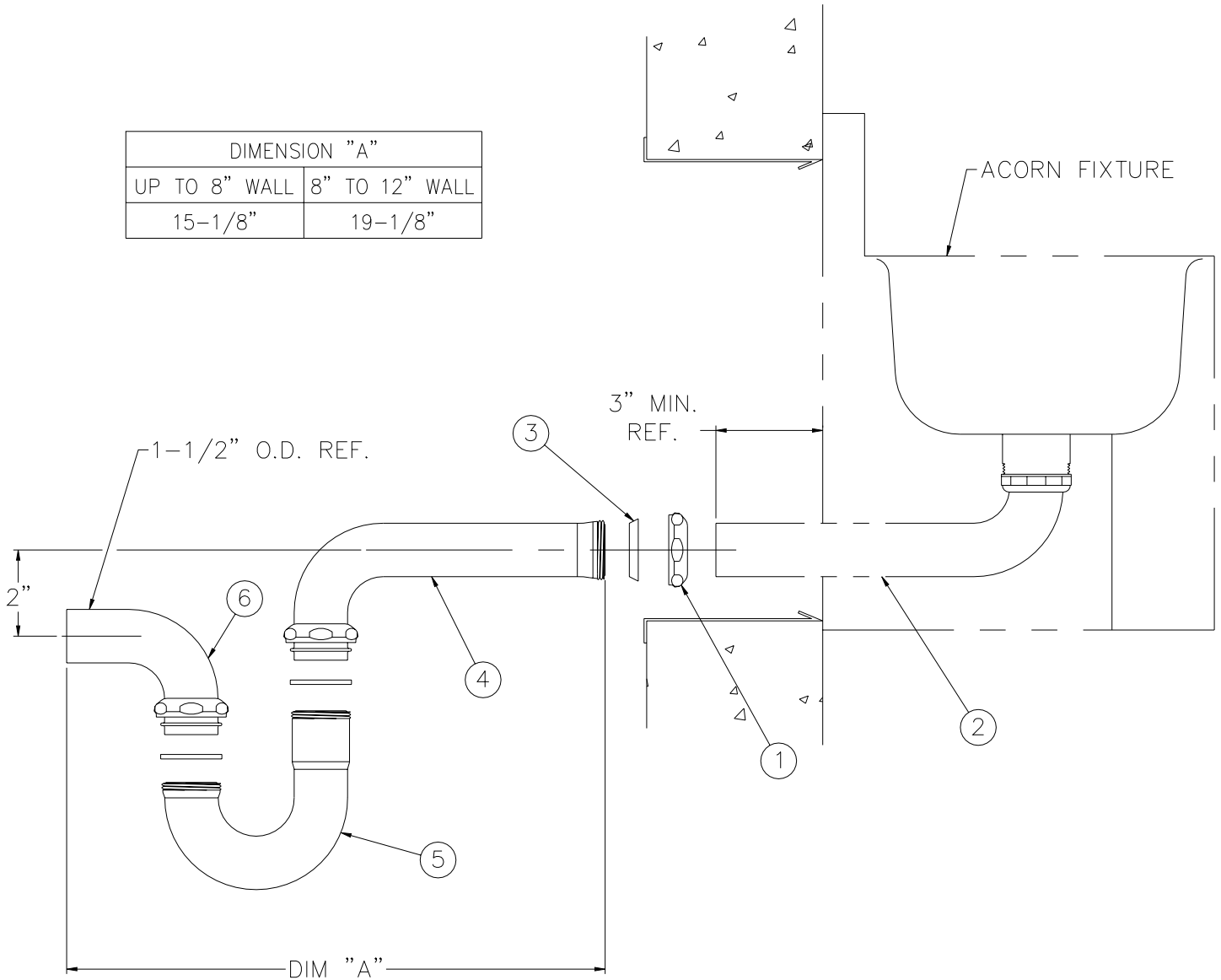

INSTALLATION INSTRUCTIONS:

A- AFTER INSTALLING ACORN UNIT ON FINISHED WALL, SLIP COMPRESSION NUT ① OVER 1-1/2" O.D. PLAIN END WASTE ②. USING COMPRESSION GASKET ③, AND NUT ① MAKE-UP COMPRESSION CONNECTION WITH SLIP JOINT ELBOW ④.

B- REMOVABLE TUBULAR P-TRAP ⑤ CONNECTS TO SLIP JOINT ELBOW ④ AND PLAIN END ELBOW ⑥ WITH COMPRESSION CONNECTIONS AS SHOWN.

NOTE: TUBULAR P-TRAP IS REMOVABLE IN ORDER TO ALLOW FOR WASTE CLEANOUT.

<p>ACORN ENGINEERING COMPANY P.O. BOX 3527 INDUSTRY, CA. 91744 (626) 336-4561 FAX (626) 961-2200</p>	<p>TITLE LAVATORY THRU-WALL WASTE CONNECTION w/ P-TRAP & CLEANOUT CAT. # -LW1</p>	
	<p>MANUFACTURE DATE APRIL 30, 1998 TO PRESENT</p>	<p>DATE ISSUED 3/19/98</p> <p>DATE REVISED 4/23/98</p>



**MOUNTING
DETAIL
"A-A"**

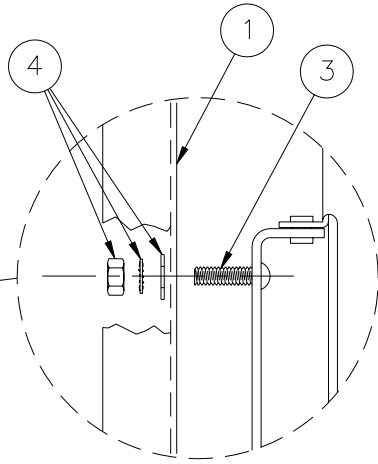

**MOUNTING
DETAIL
"B-B"**

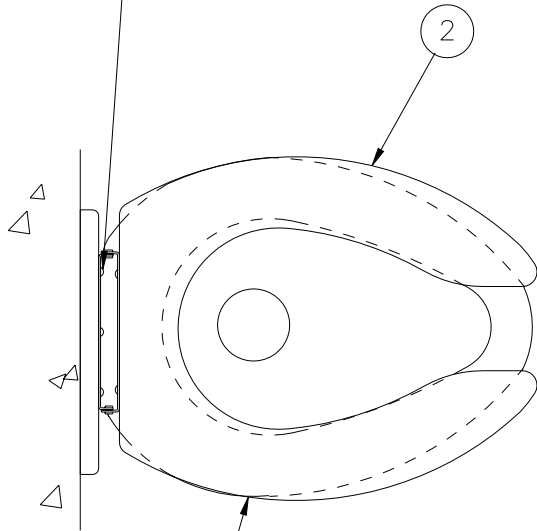
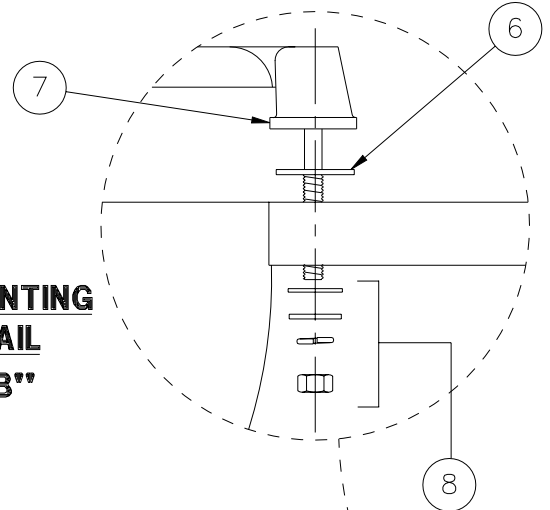

1679 TOILET
SHOWN FOR
REFERENCE
ONLY

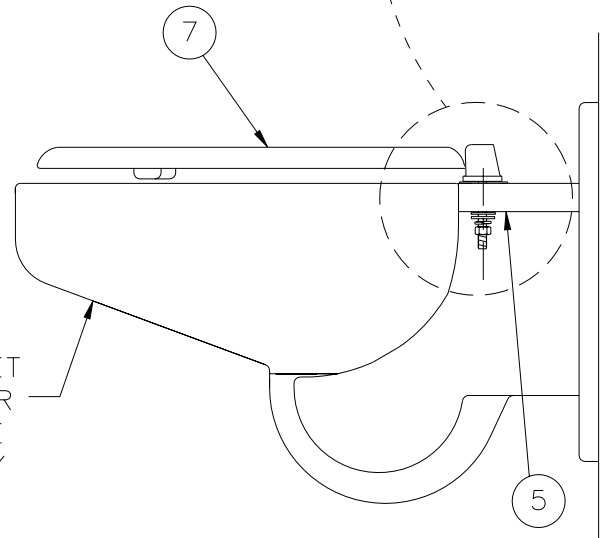

1675 TOILET
SHOWN FOR
REFERENCE
ONLY

**INSTALLATION INSTRUCTIONS-COMBY AND 1679 TOILET
PRIOR TO MOUNTING FIXTURE ON WALL:**

- A- LOCATE HINGED SEAT MOUNTING HOLES ON FIXTURE ①.
- B- POSITION HINGED SEAT ② AGAINST UNIT ① BY INSERTING SCREWS ③ INTO MOUNTING HOLES.
- C- ASSEMBLE NUT, WASHER AND LOCK-WASHER ④ AS SHOWN IN MOUNTING DETAIL "A-A".

**INSTALLATION INSTRUCTIONS-TOILETS
PRIOR TO MOUNTING FIXTURE ON WALL:**

- A- LOCATE HINGED SEAT MOUNTING HOLES IN FIXTURE ⑤.
- B- INSERT WASHERS ⑥ BETWEEN TOP OF TOILET AND HINGE SEAT ⑦.
- C- POSITION HINGED SEAT ⑦ ON TOP OF UNIT.
- D- ASSEMBLE HARDWARE ⑧ AS SHOWN IN MOUNTING DETAIL "B-B"



ACORN ENGINEERING COMPANY
P.O. BOX 3527 INDUSTRY, CA. 91744
(626) 336-4561 FAX (626) 961-2200

TITLE **-HS HINGED SEAT OPTION INSTALLATION DETAIL - COMBYS AND TOILETS**

MANUFACTURE DATE
FEBRUARY 1999
TO PRESENT

DATE ISSUED
02/22/99
DATE REVISED
03/26/01

DRAWING NUMBER
9925-048-001



Model #	Dimensions	
	"A"	"B"
1415	15"	18"
1415	18"	22"

Note:
"B" Dimensions are taken from cell side.

Model #	Dimensions	
	"A"	"B"
1420	15"	18"
1420	18"	23"

Note:
"B" Dimensions are taken from cell side.

1415-AL Angled left shown
-AR Angled right opposite

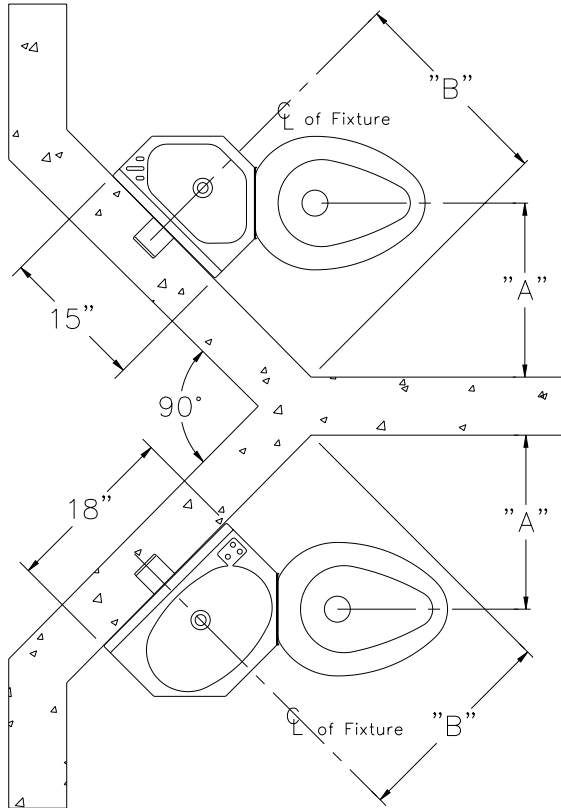

1420-AL Angled left shown
-AR Angled right opposite

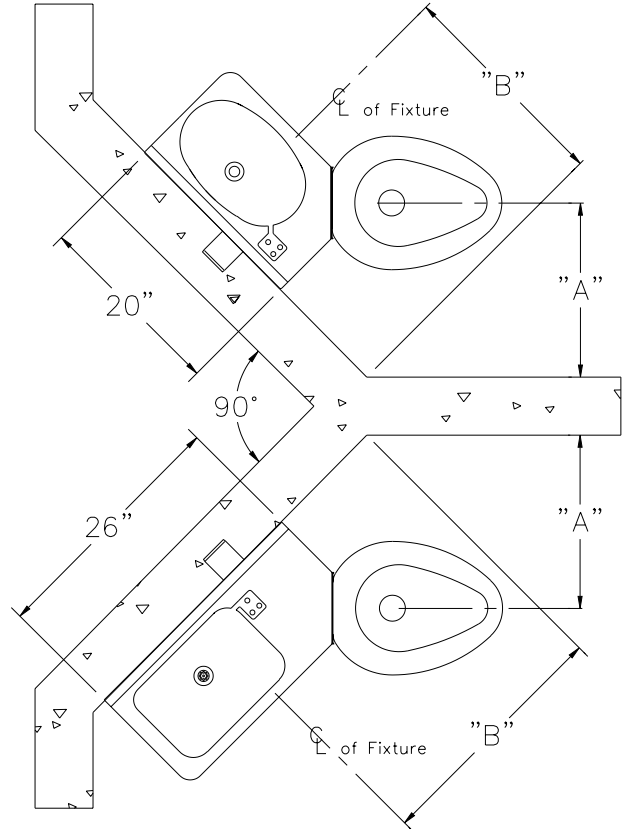

1418-AR Angled right shown
-AL Angled left opposite

Model #	Dimensions	
	"A"	"B"
1418	15"	17"
1418	18"	22"

Note:
"B" Dimensions are taken from cell side.

1426-AR Angled right shown
-AL Angled left opposite

Model #	Dimensions	
	"A"	"B"
1426	15"	21"
1426	18"	26"

Note:
"B" Dimensions are taken from cell side.

THIS SHEET IS INTENDED TO ASSIST INSTALLER WITH LOCATION OF UNIT CENTERLINE ON CHASE WALL WHEN ANGLED TOILET BOWLS ARE SPECIFIED.



ACORN ENGINEERING COMPANY
P.O. BOX 3527 INDUSTRY, CA. 91744
(626) 336-4561 FAX (626) 961-2200

TITLE **CELL LAYOUT FOR COMBY FIXTURES WITH -AL/-AR ANGLED TOILET BOWLS**

MANUFACTURE DATE
JUNE 1997
TO PRESENT

DATE ISSUED
6/5/97
DATE REVISED

DRAWING NUMBER
9925-038-001

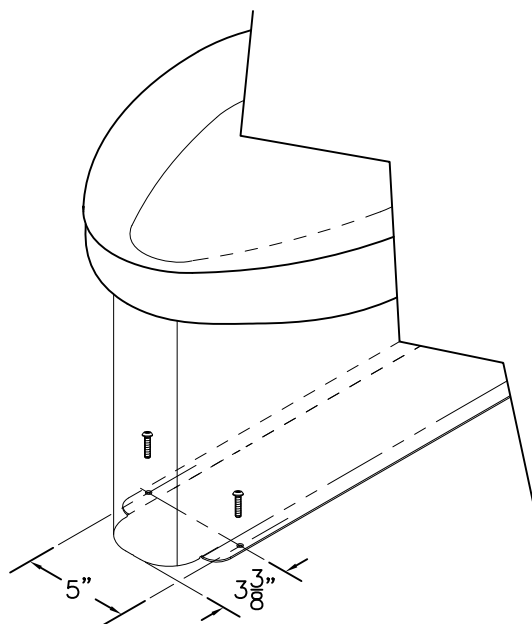
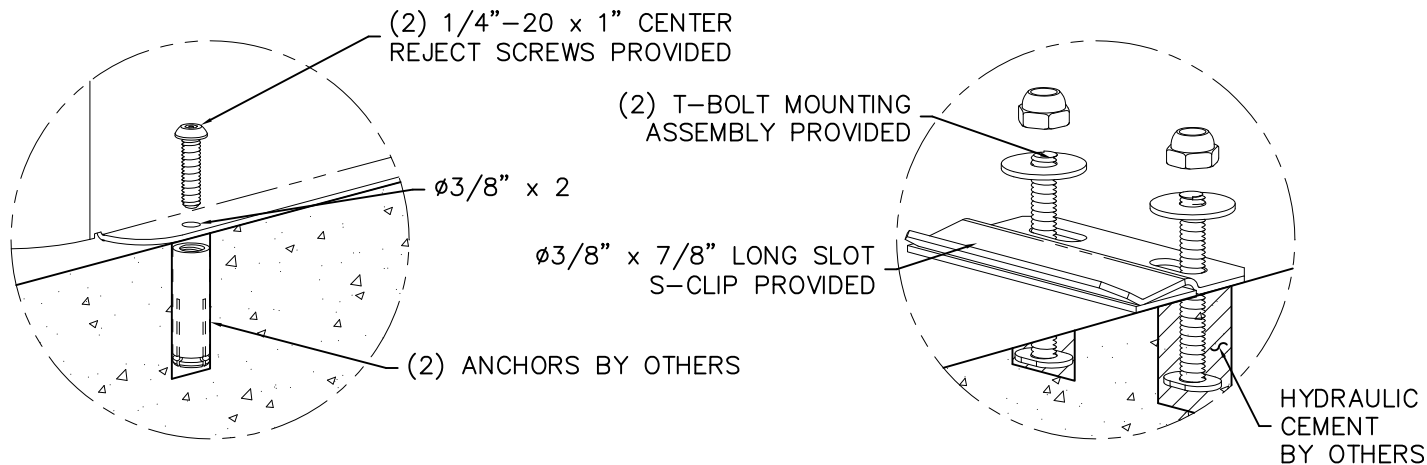

FLANGE MOUNTING

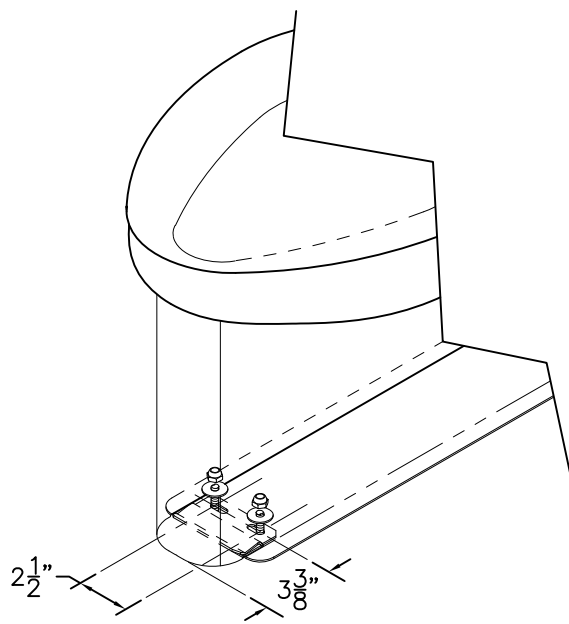

S-CLIP MOUNTING

-SS-SPS SUICIDE RESISTANT SKIRT OPTION IS PROVIDED WITH ADDITIONAL MOUNTING POINTS NOT NORMALLY PROVIDED WITH OUR STANDARD FIXTURES AND COME IN TWO STYLES AS INDICATED BELOW.

FIXTURES w/ FLANGE MOUNTING:

- A-AFTER ROUGHING IN AS REQUIRED, PLACE FIXTURE IN POSITION AND USE AS TEMPLATE TO LOCATE AND MARK FLANGE POINTS ON FLOOR.
- B-REMOVE FIXTURE AND INSTALL FLOOR ANCHORS BY OTHERS FOR 3/8" DIAMETER FLANGE PUNCHING.
- C-ALIGN WALL AND FLOOR ANCHORING POINTS AND COMPLETE FIXTURE INSTALLATION AS INDICATED BY THE FIXTURE INSTALLATION SHEET PROVIDED.

FIXTURES w/ S-CLIP:

- A-AFTER ROUGHING IN AS REQUIRED, PLACE FIXTURE IN POSITION AND USE AS A TEMPLATE TO LOCATE AND MARK S-CLIP MOUNTING LOCATION ON FLOOR AS INDICATED.
- B-REMOVE FIXTURE, INSTALL T-BOLTS FOR S-CLIP 3/8" x 7/8" LONG MOUNTING SLOTS AND SECURE WITH HYDRAULIC CEMENT (BY OTHERS)
- C-INSTALL S-CLIP
- D-PLACE FIXTURE ON FLOOR POSITIONING THE "NOSE" OF THE SKIRT SEVERAL INCHES IN FRONT OF S-CLIP MOUNTING LOCATION, SLIDE FIXTURE INTO PLACE ENGAGING THE S-CLIP AND ALIGNING WALL MOUNTING LOCATIONS. COMPLETE FIXTURE INSTALLATION AS INDICATED BY THE FIXTURE INSTALLATION SHEET PROVIDED.



ACORN ENGINEERING COMPANY
P.O. BOX 3527 Industry, CA 91744
15125 Proctor Ave Industry, CA 91746
(626) 336-4561 FAX (626) 961-2200

TITLE **-SPS MOUNTING DETAIL**

MANUFACTURE DATE
AUGUST 2012
TO PRESENT

DATE ISSUED
08/15/12
DATE REVISED
11/05/13 A

DRAWING NUMBER
9925-007-001